

MAGNETIC HOLDERS

Types of magnetic holders

Product Name	Model	Application
Electromagnetic holder	KE-B·E(D)·R·K·V·M	Used for automation of press machines and shearing robots. Imbedded in molds. Holding various workpieces.
Permanent electromagnetic holder	KEP·KE-HA	
Permanent magnetic holder	KM	

※Also see the Facsimile Communication Form (Selection Data) at the end of this Catalog.

Model KE-B ELECTROMAGNETIC HOLDER

Useful for automated manufacturing lines as the magnetic force can be turned on and off or increased/decreased or operated remotely via a rectifier (to be installed additionally).

Rectifier required additionally



[Application]

These holders are suitable for a wide range of operations such as feeding materials on automatic press machines, preventing deflection of shearing materials, various automatic processes and hands of industrial robots.

[Features]

- Special cables that have specially high durability against bending and vibration are used. (Employed in all models except for KE-1B.)
- Electrical control can be used for turning on and off the magnetic force and for remote operation.
- Usable continuously.
- Finished by plating.

A type of cord on the top face spec. (KE-B-U) is also available.

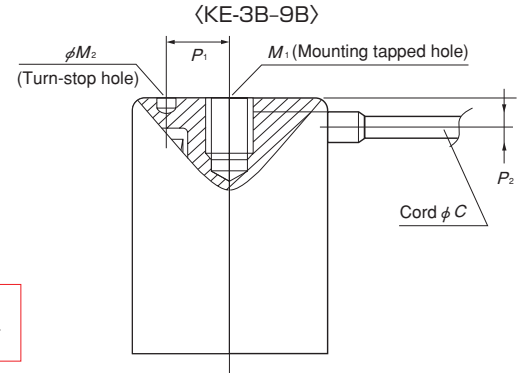

Precautions for use

Rust and scratches on the attractive face affect the holding power adversely. Repair it periodically. When used continuously, the holder will become very hot. Exercise caution.

KE-2B/3B/4B/5B

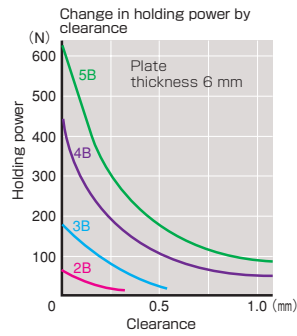
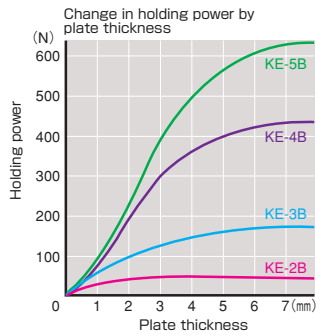

KE-5E/6E/6B/7B/8B/9B

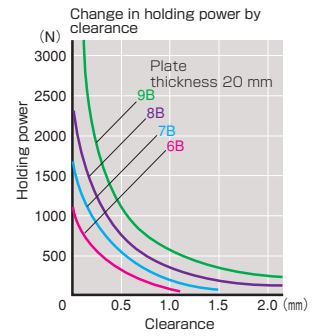
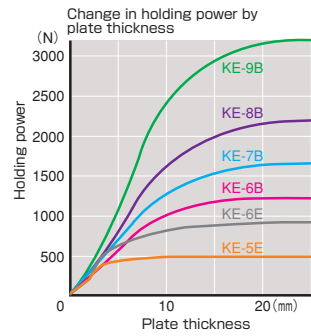

Model	Nominal Size	Max. Holding Power	Mounting Hole			Power Cord		Voltage	Current	Working Rate	Applicable Rectifier	Mass
			M ₁	M ₂	P ₁	C	P ₂					
KE-1B	φ 10 (0.39) × 30 (1.18)	8N (0.8kgf)	M4 (0.15) × 0.7 (0.02) Depth 6 (0.23)	-	-	-	-	6 VDC	0.18A	100% ED	KR-T101A-6/24 RH-M303A-6/24, -C1, -C2	15g/0.03 lb
KE-1.5B	φ 15 (0.59) × 40 (1.57)	18N (1.8kgf)										
KE-2B	φ 20 (0.78) × 40 (1.57)	28N (2.8kgf)	φ 4 (0.15) × 0.7 (0.02) Depth 6 (0.23)	-	-	-	7 (0.27)	24 VDC	0.07A	100% ED	KR-T101A-6/24 RH-M303A-6/24, -C1, -C2 RH-M105B-24	60g/0.13 lb
KE-3B	φ 30 (1.18) × 40 (1.57)	180N (18kgf)										
KE-4B	φ 40 (1.57) × 40 (1.57)	400N (40kgf)	φ 4 (0.15) × 0.7 (0.02) Depth 6 (0.23)	φ 4 (0.15) × 0.7 (0.02) Depth 3 (0.11)	15 (0.59)	-	8.5 (0.33)	24 VDC	0.24A	100% ED	KR-T101A-6/24 RH-M303A-6/24, -C1, -C2 RH-M105B-24	150g/0.33 lb
KE-5B	φ 50 (1.96) × 50 (1.96)	590N (60kgf)										
KE-6B	φ 60 (2.36) × 60 (2.36)	1080N (110kgf)	M8 (0.31) × 1.25 (0.04) Depth 15 (0.59)	φ 5 (0.19) × 0.7 (0.02) Depth 4 (0.15)	18 (0.70)	-	10 (0.39)	90 VDC	0.12A	100% ED	KR-N101A KR-N103A RH-M102C RH-M105B RH-M205B	560g/1.23 lb
KE-7B	φ 70 (2.75) × 60 (2.36)	1470N (150kgf)										
KE-8B	φ 80 (3.15) × 60 (2.36)	1960N (200kgf)	M10 (0.39) × 1.5 (0.05) Depth 15 (0.59)	φ 6 (0.23) × 0.7 (0.02) Depth 6 (0.23)	20 (0.78)	-	15 (0.59)	90 VDC	0.20A	100% ED	KR-N101A KR-N103A RH-M102C RH-M105B RH-M205B	1.0kg/2.20 lb
KE-9B	φ 90 (3.54) × 60 (2.36)	3230N (330kgf)										

※Cord length 0.3 m (0.25 m lead for KE-1B and KE-1.5B only)

※The max. holding power of Models KE-1B to 4B is based on a test piece of SS400, 10 mm thick, ground surface held on the whole area, and that of KE-5B to 9B, a test piece of SS400, 20 mm thick, ground surface held on the whole area.

※For KE-3B to 9B, a drip-proof type is also available.

1N≒0.1kgf

ELECTROMAGNETIC CHUCKS
PERMANENT MAGNETIC CHUCKS
BLOCKS FOR MC
VACUUM CHUCKS
PROMELTA*
SINE BAR CHUCKS
BLOCKS HOLDERS
HOLDING TOOLS
MEASURING TOOL HOLDERS
MAGNETIC HOLDERS
MAGNETIC TOOLS

Model **KE-D·E** THIN ELECTROMAGNETIC HOLDER



Rectifier required additionally

[Application]

Thin electromagnetic holders suitable for a robotic hand as they provide vertical motion in a certain range in limited space.

[Features]

- Special cables that have specially high durability against bending and vibration are used. (Employed in all models except for KE-2D.)
- Usable continuously.
- Finished by plating.

A type of cord on the top face spec. (KE-E-U) is also available.

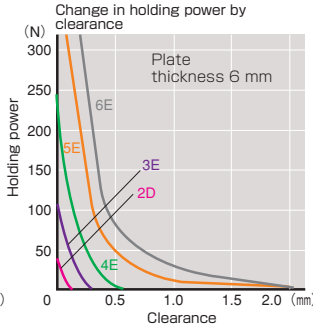
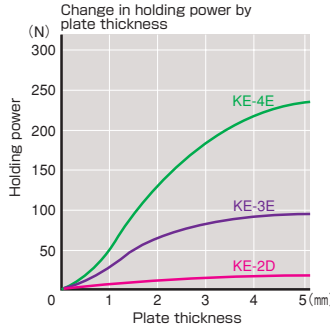

⟨KE-3-6E⟩

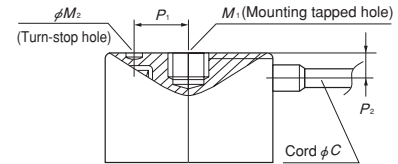

Precautions for use

Rust and scratches on the attractive face affect the holding power adversely. Repair it periodically. When used continuously, the holder will become very hot. Exercise caution.

Model	Nominal Size	Max. Holding Power	Mounting Hole			Power Cord		Voltage	Current	Working Rate	Applicable Rectifier	Mass
			M ₁	M ₂	P ₁	C	P ₂					
KE-2D	φ20 (0.78) × 25 (0.98)	18N (1.8kgf)	M4 (0.15) × 0.7 (0.02) Depth 8 (0.31)	φ2.1 (0.08) Depth 2.5 (0.09)	7.5 (0.29)	—	—	24 VDC	0.04A	100% ED	KR-T101-6/24 RH-M303A-6/24, -C1, -C2 RH-M105B-24	30g/0.06 lb
KE-3E	φ30 (1.18) × 25 (0.98)	80N (8kgf)	M6 (0.23) × 1.0 (0.03) Depth 12 (0.47)	φ4 (0.15) Depth 2 (0.07)	10 (0.39)	φ3.5 (0.13)	7.5 (0.29)	24 VDC	0.09A		100g/0.22 lb	
KE-4E	φ40 (1.57) × 25 (0.98)	220N (22kgf)	M8 (0.31) × 1.25 (0.04) Depth 15 (0.59)	φ4 (0.15) Depth 2.5 (0.09)	15 (0.59)	φ3.5 (0.13)	8 (0.31)	24 VDC	0.12A		190g/0.42 lb	
KE-5E	φ50 (1.96) × 30 (1.18)	490N (50kgf)	M8 (0.31) × 1.25 (0.04) Depth 15 (0.59)	φ5 (0.19) Depth 3 (0.11)	18 (0.70)	φ3.5 (0.13)	9.5 (0.37)	90 VDC	0.05A	100% ED	KR-N101A RH-M105B KR-N103A RH-M205B RH-M102C RH-M210B	380g/0.83 lb
KE-6E	φ60 (2.36) × 30 (1.18)	880N (90kgf)	M8 (0.31) × 1.25 (0.04) Depth 15 (0.59)	φ5 (0.19) Depth 4 (0.15)	20 (0.78)	φ3.5 (0.13)	11 (0.43)	90 VDC	0.07A		500g/1.10 lb	

※ Cord length 0.3 m (0.2 m lead for KE-2D only) ※ The max. holding power is based on a test piece of SS400, 10 mm thick, ground surface held on the whole area. 1N≅0.1kgf

Model **KE-R** AUTO RELEASE TYPE ELECTROMAGNETIC HOLDER

Rectifier required additionally

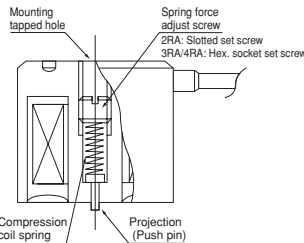
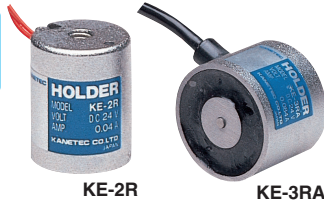

[Application]

Suitable as a hand of industrial robots for transportation of press workpieces that are small and light to make them difficult to be released by their own weight only.

[Features]

- Special cables that have specially high durability against bending and vibration are used. (Employed in all models except for KE-2R.)
- The workpiece is released quickly by the spring force of the projection in the center of the attractive face. The spring force can be adjusted according to workpiece conditions.
- The workpiece can be attracted and released smoothly.
- Finished by plating.
- Usable continuously.

※ Use these holders for workpieces whose surface where the holder comes in contact is not rough or has no holes. These holders are not suitable either for thin sheets that may be deformed by the pressing force.

A type of cord on the top face spec. (KE-RA-U) is also available.

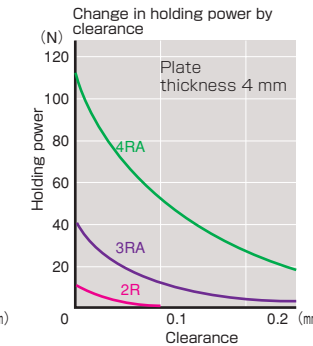
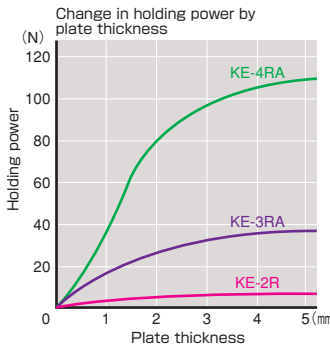

Precautions for use

Rust and scratches on the attractive face affect the holding power adversely. Repair it periodically. When used continuously, the holder will become very hot. Exercise caution.

Model	Nominal Size	Max. Holding Power	Center Tapped Hole on Back	Voltage	Current	Working Rate	Applicable Rectifier	Mass
KE-3RA	φ30 (1.18) × 25 (0.98)	40N (4kgf)	M6 (0.23) × 1.0 (0.03) Depth 6 (0.23)	24 VDC	0.09A	100g/0.22 lb		
KE-4RA	φ40 (1.57) × 25 (0.98)	100N (10kgf)	M6 (0.23) × 1.0 (0.03) Depth 7.5 (0.29)	24 VDC	0.12A	200g/0.44 lb		

※ The projection is provided in the center of the attractive face; φ2 φ max. length 1mm for KE-2R and φ2.5 φ max. length 1 mm for KE-3RA and 4RA. ※ Cord length 0.3 m (0.2 m lead for KE-2R only) ※ The max. holding power is based on a test piece of SS400, 10 mm thick, ground surface held on the whole area.

※ Allowable temperature: The electromagnetic holders KE, permanent electromagnetic holders KEP and hybrid holders KE-H must be used under the conditions of ambient temperature 40°C or below and temperature of workpieces to hold 50°C or below. For higher temperature, please contact us.

※ The holding power of KE-B, KE-E (D) and KE-RA (R) on various thickness of steel plates and the holding power relative to various clearance are as shown by the graphs.

※ The max. holding power is the power that can be obtained under the most favorable conditions including materials, shapes and finishes of workpieces to hold. Therefore, for practical use, choose a suitable model in consideration of a large drop in the holding power depending on situations. Generally, the lifting capacity drops to a half or below of the holding power obtained from the graphs. If you plan to use holders in

particular situations such as for workpieces having holes or grooves on the attractive face to disable the utilization of the whole area or where big acceleration (G) will be applied to workpieces to be held and transported, please contact us.

※ The electromagnetic holders have residual magnetism even after they are powered off. If the mass of the workpiece is greater than the residual holding power, the workpiece will come off, but if not, it is usually necessary to use a rectifier equipped with a reduction-of-magnetization function by reverse excitation, except for the holders equipped with the automatic release function.

※ The electromagnetic holders are not of drip-proof construction. If drip-proof holders are required, please contact us.

※ If you want to use an uninterruptible power supply as a rectifier for electromagnetic holders, please consult with us in advance.

ELECTROMAGNETIC CHUCKS
CHUCKS
PERMANENT ELECTROMAGNETIC CHUCKS
MAGNETIC CHUCKS
CONTRACTORS
PERMANENT ELECTROMAGNETIC CHUCKS
MAGNETIC CHUCKS
FOR MC
VACUUM CHUCKS
PROMELTA* SYSTEM
SINE BAR CHUCKS
BLOCKS HOLDERS, MINI CHUCKS
HOLDING TOOLS
MEASURING TOOL HOLDERS
MAGNETIC HOLDERS
MAGNETIC TOOLS

MAGNETIC HOLDERS

Model KE-K RECTANGULAR THIN ELECTROMAGNETIC HOLDER

Rectifier required additionally

An example of coupling

[Application]

Suitable for automated processing systems where workpieces are lifted and moved/transported by limited strokes in a space the vertical distance of which is short. These holders are suitable for a wide range of operations such as feeding materials on automatic press machines, preventing deflection of shearing materials, various automatic processes and hands of industrial robots.

[Features]

- Usable continuously.
- As thin as 15 mm to 20 mm, yet powerful magnetic force.

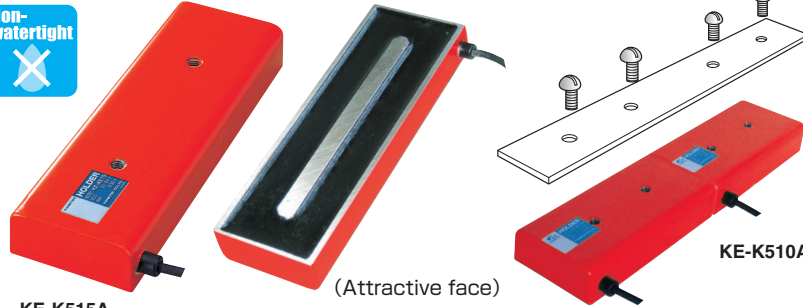

KE-K515A

(Attractive face)

KE-K510A

[mm (in)]

Model	Dimensions						Max. Holding Power	Voltage	Current	Working Rate	Applicable Rectifier	Mass
	B	H	H ₁	L	P	d						
KE-K310A	30 (1.18)	15 (0.59)	6.5 (0.25)	100(3.93)	40(1.57)	M4(0.15) Depth 6(0.23)	70N(7kgf) 100N(10kgf)	24 VDC	0.11A 0.20A	100% ED	KR-T101A-6/24 RH-M303A-6/24, -C1, -C2	0.2 kg/0.44 lb 0.3 kg/0.66 lb
KE-K510A	50 (1.96)	20 (0.78)	9.0 (0.35)	100(3.93)	40(1.57)	M6(0.23) Depth 8(0.31)	180N(18kgf) 260N(26kgf)		0.17A 0.30A			RH-M105B-24

※The max. holding power is based on a test piece of 12 mm thick steel plate. ※Cord length 0.3 m

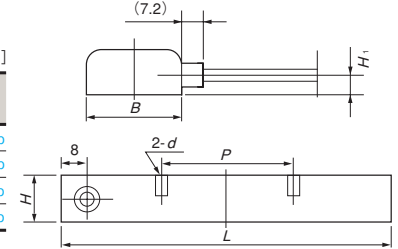

Model KE-V V-TYPE ELECTROMAGNETIC HOLDER

Rectifier required additionally

[Application]

The V-shaped attractive face makes these holders suitable for automatic unloading, transferring and feeding thin sheets, round bars, irregularly shaped workpieces (doughnut-shaped workpieces, etc.) and pipes.

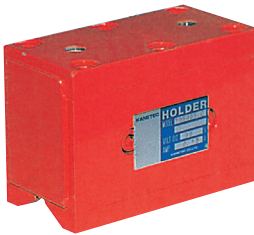

KE-V515



Precautions for use

Rust and scratches on the attractive face affect the holding power adversely. Repair it periodically.

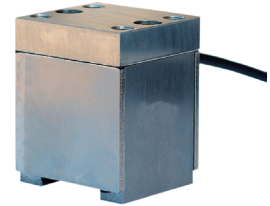
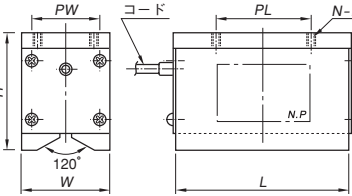

An example of special construction designed for small ring-shaped workpieces (Attractive face □ shaped)

Model	Dimensions						Max. Holding Power [N(kgf)]				Applicable Round Bar Dia.	Voltage	Current	Working Rate	Applicable Rectifier	Mass	
	W	H	L	PW	PL	N	M	φ10	φ30	φ50							φ80
KE-V306	30	50	60(2.36)	-	30(1.18)	2	M6(0.23) Depth 10(0.39)	150(15)	250(25)	-	-	300(30)	24 VDC	100% ED	RH-M303A-6/24, -C1, -C2 RH-M105B-24 KR-T101A-6/24	0.6kg/1.32 lb 0.9kg/1.98 lb 1.1kg/2.42 lb	
KE-V309	30	50	90(3.54)		50(1.96)			800(80)	φ10(0.39) - φ30(1.18)			0.23A 0.32A					
KE-V312	30	50	120(4.72)		70(2.75)			1300(130)	0.44A								
KE-V510	50	70	100(3.93)	-	80(3.15)	M8(0.31) Depth 10(0.39)	800(80)	1200(120)	-	-	1800(180)	90 VDC	100% ED	RH-M102C RH-M105B RH-M205B RH-M210B KR-N101A KR-N103A	2.2kg/4.85 lb 3.0kg/6.61 lb 4.0kg/8.80 lb 6.5kg/14.3 lb 10kg/22.0 lb		
KE-V515			150(5.90)				1300(130)	2200(220)			3200(320)					φ26(1.02) - φ50(1.96)	0.2A
KE-V520			200(7.87)				1800(180)	3200(320)			4500(450)					φ40(1.57) - φ80(3.15)	0.27A
KE-V815	75	100	150(5.90)	50	80(3.15)	M8(0.31) Depth 12(0.47)	1600(160)	2000(200)	-	-	4000(400)	90 VDC	100% ED	RH-M102C RH-M105B RH-M205B RH-M210B KR-N101A KR-N103A	2.2kg/4.85 lb 3.0kg/6.61 lb 4.0kg/8.80 lb 6.5kg/14.3 lb 10kg/22.0 lb		
KE-V823			225(8.85)				3000(300)	4000(400)			7000(700)					0.66A	
KE-V830			300(11.8)				4500(450)	6000(600)			10000(1000)					0.75A	

※Cord length 0.3 m. ※The max. holding power on round steel bars is based on cold finished steel bars held on the whole area.
※The max. holding power on flat steel plates is based on a test piece of SS400, 50 mm thick, ground surface held on the whole face.

Model KE-M ROD TYPE ELECTROMAGNETIC HOLDER

Rectifier required additionally

[Application]

Mainly suitable for automatic transfer and feeding of irregular-shaped parts such as castings in the automotive industry.

[Features]

These holders have a single long pole enabling it to lift parts that are randomly placed in buckets one by one by adjusting the voltage with the rectifier.



KE-M2



Precautions for use
Rust and scratches on the attractive face affect the holding power adversely. Repair it periodically.

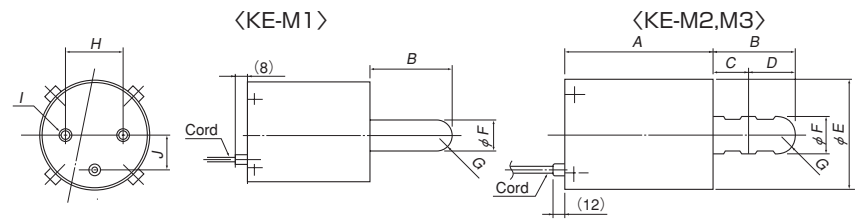

Model	Dimensions										Max. Holding Power	Voltage	Current	Working Rate	Applicable Rectifier	Mass
	A	B	C	D	E	F	G	H	I	J						
KE-M1	60 (2.36)	40 (1.57)	-	-	50.8 (2.00)	12 (0.47)	SR6 (0.23)	30 (1.18)	2-M6(0.23) Depth 10(0.39)	15 (0.59)	20N(2kgf)	90 VDC	50% ED	RH-M102C RH-M105B RH-M205B RH-M210B KR-N101A KR-N103A	0.8kg/1.76 lb 3.5kg/7.71 lb 10kg/22.0 lb	
KE-M2	100 (3.93)	55 (2.16)	25 (0.98)	30 (1.18)	76.3 (3.00)	25 (0.98)	SR12.5 (0.49)	50 (1.96)	2-M8(0.31) Depth 12(0.47)	25 (0.98)	90N(9kgf)					
KE-M3	160 (6.29)	80 (3.15)	30 (1.18)	50 (1.96)	114.3 (4.50)	35 (1.37)	SR17.5 (0.69)	80 (3.15)	2-M12(0.47) Depth 20(0.78)	40 (1.57)	250N(25kgf)					

※50% ED (Repeating cycle of power on 5 minutes and pause 5 minutes). ※Cord length 0.3 m.
※The max. holding power is based on such usage that the tip is brought into contact with the flat surface of an SS400 block and pulled up vertically.

ELECTROMAGNETIC CHUCK CONTROLLERS; PERMANENT MAGNETIC CHUCKS; ELECTROMAGNETIC CHUCKS; BLOCKS FOR MC; VACUUM CHUCKS; PROMELTA; SINE BAR CHUCKS; BLOCKS HOLDERS; MINICHUCKS; HOLDING TOOLS; MEASURING TOOL HOLDERS; MAGNETIC HOLDERS; MAGNETIC TOOLS

Model **KEP** PERMANENT ELECTROMAGNETIC HOLDER



Electromagnetic release

Rectifier required additionally

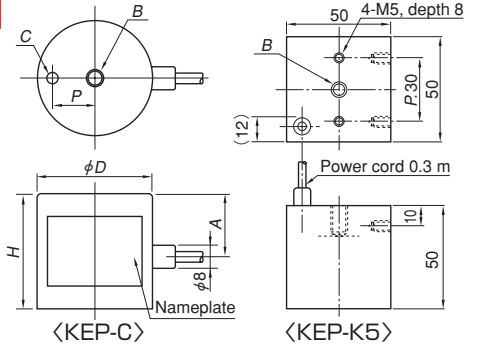
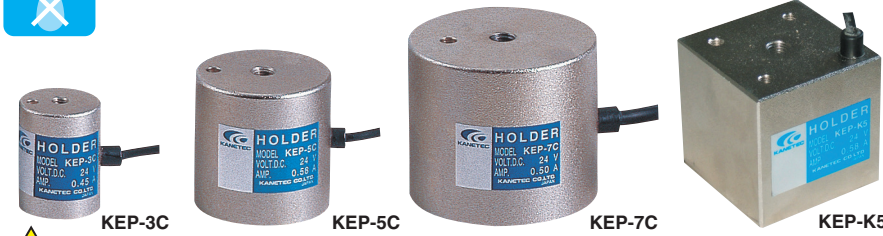

Precautions for use
Rust and scratches on the attractive face affect the holding power adversely. Repair it periodically.

[Features]

- No fear of accidents by fallen workpieces due to power failure and no heat generated by continuous power on. These features make these holders suitable for long-hour holding. Workpieces are held by a permanent magnet, but its ON/OFF is controlled electrically.
- The electromagnetic release type that keeps the magnetic force off when power is being supplied. Normally, the magnetic force is kept ON.
- An uninterruptible power supply is not required.
- The square type (KEP-K) is suitable for picking up small parts from corners of containers, etc. and picking up doughnut-shaped workpieces.

How to use

Obtain 24 VDC power source. Connect the power cord with positive and negative wires as shown below:

- Connect the black wire of the cord to the positive terminal of the power source.
- Connect the white wire of the cord to the negative terminal of the power source.

If the positive and negative wires are reversed, workpieces cannot be released.

Released only at power on

The power-on time must be 5 seconds or less. The power-off time must be 10 times or longer. (30 seconds or less for KEP-K.)

Residual holding power

As an inevitable nature of permanent electromagnetic holders, 3% to 4% of the holding power will remain as residual holding power after the workpiece has been released. If the weight of the lifted workpiece is smaller than this holding power, it may not be released. In such a case, the workpiece can be released easily by attaching a thin nonmagnetic film on the attractive face. Note, however, that the holding power will drop as the square of clearance.

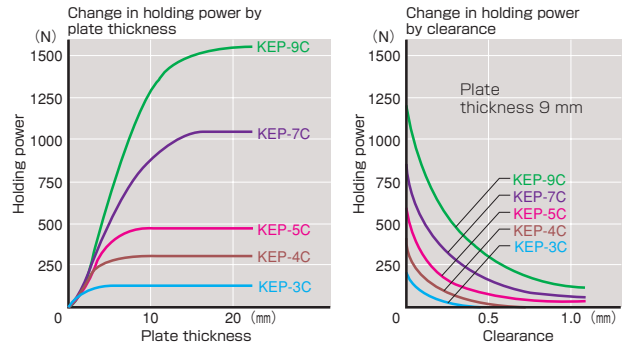

Model	Dimensions						Max. Holding Power	Voltage	Current	Working Rate	Applicable Rectifier	Mass
	φD	H	P	A	B	C						
KEP-3C	30 (1.18)	40	10 (0.39)	22 (0.86)	M6 (0.23) Depth 10 (0.39)	φ4 (0.15) Depth 3 (0.11)	150N (15kgf)	24 VDC	0.45A	10% ED	RH-M303A-6/24 RH-M303A-6/24-C1 RH-M303A-6/24-C2 KR-T101A-6/24	0.17kg/ 0.37 lb
KEP-4C	40 (1.57)	40	15 (0.59)	22 (0.86)	M6 (0.23) Depth 10 (0.39)	φ4 (0.15) Depth 3 (0.11)	250N (25kgf)		0.54A			0.31kg/ 0.68 lb
KEP-5C	50 (1.96)	50	18 (0.70)	25 (0.98)	M8 (0.31) Depth 13 (0.51)	φ5 (0.19) Depth 4 (0.15)	340N (35kgf)		0.58A			0.6 kg/ 1.32 lb
KEP-7C	70 (2.75)	60	20 (0.78)	35 (1.37)	M10 (0.39) Depth 16 (0.62)	φ6 (0.23) Depth 6 (0.23)	880N (90kgf)		0.50A			1.5 kg/ 3.30 lb
KEP-9C	90 (3.54)	60	20 (0.78)	35 (1.37)	M10 (0.39) Depth 16 (0.62)	φ6 (0.23) Depth 6 (0.23)	1470N (150kgf)		0.45A			2.4 kg/ 5.29 lb
KEP-K5	50 (1.96)	50 (1.96)	50 (1.96)	50 (1.96)	M8 (0.31) Depth 13 (0.51)	—	250N (25kgf)		0.43A			50% ED

*The max. holding power is based on a test piece of SS400, 20 mm thick, ground surface held on the whole area. Therefore, the lifting capacity is normally a third or less of the max. holding power. *Cord length 0.3 m.

Model **KE-H** HYBRID HOLDER

Controller required additionally

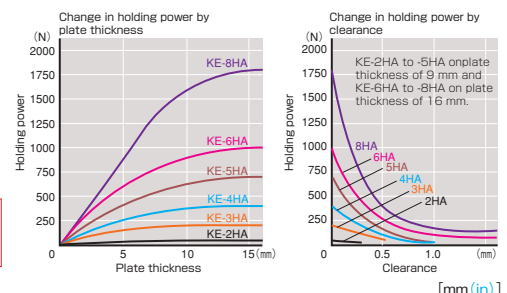

Precautions for use
Rust and scratches on the attractive face affect the holding power adversely. Repair it periodically.

[Application]

Suitable for robot hands and such systems that require high-speed operations such as repeated transfer in automated lines.

[Features]

- Very little residual holding power allows workpieces to be released quickly. This enables high-speed operation; for example, light weight workpieces can be attached/detached 5 to 6 times per second.
- Because these holders are of permanent electromagnetic type, the holders consume little power and generate little heat, making these holders suitable for continuous, long-hour operation.
- The holding power is switchable at two stages; High and Low by turning on and off the power supply. The reverse supply of power releases workpieces. This enables a wide variety of usage. (When at "Low," the holding power is about 1/3 of that at "High.")
- The powerful rare earth magnet offers high holding power in spite of its small size.

A type of cord on the top face spec. (KE-HA-U) is also available.

Model	Size	Max. Holding Power	Center Tapped Hole on Back	Voltage	Current	Working Rate	Applicable Rectifier	Mass
KE-2HA	φ20 (0.78) × 25 (0.98)	50N (5kgf)	M4 (0.15) × 0.7 (0.02) Depth 6 (0.23)	24 VDC	0.07A	100% ED	RH-H303A RH-H303A-C2	60g/ 0.13 lb
KE-3HA	φ30 (1.18) × 40 (1.57)	200N (20kgf)	M6 (0.23) × 1.0 (0.03) Depth 6 (0.23)		0.11A			140g/ 0.31 lb
KE-4HA	φ40 (1.57) × 40 (1.57)	400N (40kgf)			0.15A			280g/ 0.61 lb
KE-5HA	φ50 (1.96) × 50 (1.96)	700N (70kgf)	M8 (0.31) × 1.25 (0.04) Depth 10 (0.39)		0.2 A			530g/ 1.17 lb
KE-6HA	φ60 (2.36) × 60 (2.36)	1000N (100kgf)			0.22A			960g/ 2.11 lb
KE-8HA	φ80 (3.15) × 60 (2.36)	1800N (180kgf)			M10 (0.39) × 1.5 (0.05) Depth 12 (0.47)			0.28A

*Cord length 0.3 m. (KE-2HA: 0.2 m)

*The max. holding power is based on a test piece of SS400, ground surface held on the whole area. Therefore, the lifting capacity is normally a third or less of the max. holding power. Test piece thickness: KE-2HA to 4HA ... 10 mm, KE-5HA to 8HA ... 20 mm

ELECTROMAGNETIC CHUCKS
CHUCK CONTROLLERS
PERMANENT ELECTROMAGNETIC CHUCKS
PERMANENT ELECTROMAGNETIC CHUCKS
BLOCKS FOR MC
VACUUM CHUCKS
PROMELTA* SYSTEM
SINE BAR CHUCKS
BLOCKS HOLDERS, MINI CHUCKS
HOLDING TOOLS
MEASURING TOOL HOLDERS
MAGNETIC HOLDERS
MAGNETIC TOOLS

MAGNETIC HOLDERS

Model RH-M ELECTROMAGNETIC HOLDER HIGH-SPEED CONTROLLER

Dedicated to electromagnetic holders



RH-M102C



Precautions for use

- The rectifier KR Series and RH Series use electronic PC boards and small relays inside the rectifiers and therefore, are not suitable for use, for example, on cranes where they are subjected to vibrations constantly. For installation in places that are subjected to constant vibrations, anti-vibration measures need to be provided. The RH Series external signal input cables must be shielded cables and must be limited to 10 m long max.
- For failures due to use of holders made by other manufacturers, we may not be able to answer technical questions. Such use also voids the warranty even if a failure occurs within the warranty period.

[Application]

These are breakthrough electric products that can make standard electromagnetic holders respond to higher-speed motion of workpiece handling by robot hands, etc.

[Features]

- The residual holding power, a factor to delay workpiece attaching and detaching operations, can be eliminated quickly to speed up the lines that use standard electromagnetic holders. (The demagnetizing time may become longer depending on materials of workpieces.)
- These controllers can be used to attract and transfer stacked plates one by one or to pick up parts stored in a bucket one by one by adjusting the voltage.

Terminal wiring diagram

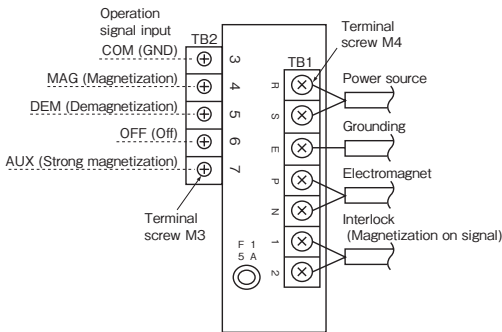

For external control by a programmable controller, connect operation signals to the terminal TB2.

Connect the dry "a" contact of a relay or switch to be provided by the customer to between the terminals ③ (COM) and each of the operation signal terminals ④ to ⑦.

For all operation signals, use a one-shot no-voltage "a" contact signal, approx.100 ms (standard).

Model	Input		Output		Dimensions			Demag. Function	Applicable Holder	Mass
	Voltage	Voltage	Voltage	Current	Width	Depth	Height			
RH-M303A-6/24	Single-phase 100 VAC - 220 VAC, 50/60 Hz	0-24 VDC/ 0-6 VDC	3A	175 (6.89)	55 (2.17)	160 (6.30)	175 (6.89)	Provided	6V KE-1B	0.8kg/ 1.76 lb
RH-M303A-6/24-C1					70 (2.76)	180 (7.09)	205 (8.07)		24V KE-2B-4B KE-2D-4E KE-2R-4RA KE-KA KE-V306-312 KEP-3C-9C,K5	1.7kg/ 3.75 lb
RH-M303A-6/24-C2					175 (6.89)	100 (3.94)	190 (7.48)		90V KE-5B-9B KE-5E,6E KE-V510-830 KE-M	4.3kg/ 9.48 lb
RH-M102C	Single-phase 100 VAC 50/60Hz	0-90 VDC	2A	145 (5.70)	175 (6.88)	260 (10.2)	Provided	24V KE-2B-4B KE-2D-4E KE-KA KE-V306-312 KE-2R-4RA	4.5kg/ 9.92 lb	
RH-M105B-24		0-24 VDC	5A	170 (6.69)				90V KE-5B-9B KE-5E,6E KE-V510-830 KE-M	6.0kg/ 13.2 lb	
RH-M105B	Single-phase 200 VAC 50/60Hz	0-90 VDC	10A	282 (11.1)	290 (11.4)					
RH-M205B		0-90 VDC								
RH-M210B										

※ For ON/OFF control, external control is required. Input signals are to be provided by the customer.

RH-M303A-6/24 Series

[Features]

- The employment of FET in the output circuit ensures high-speed and consistent demagnetization performance. This Series also withstands frequent usage.
- The PWM output control provides consistent output voltages not affected by voltage fluctuation and difference of power source frequency at very weak output setting.
- A wide range of power source from 100 VAC to 220 VAC can be used.
- The rated output voltage can be selected between 24 V and 6 V with a dip switch. (KE-1B also supported.)
- The demagnetization function is incorporated. (Alternate attenuation and reverse excitation can be selected with a dip switch.)
- A weak magnetization adjust function is incorporated.

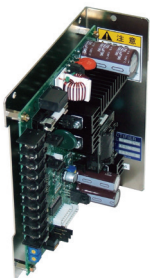

RH-M303A-6/24
[Type installed inside panel]
A simple construction of PWB and chassis suitable for installation inside the machine power source panel.



RH-M303A-6/24-C1
[Cover type]
A type having a dedicated cover added to the type installed inside panel. A power indicator lamp is provided on the panel.



RH-M303A-6/24-C2
[Type housed in case]
The base construction is the type installed inside panel. This is placed in a dedicated case to enable installation on the side face of a machine. This type is equipped with a power indicator lamp, voltmeter, magnetic force adjust variable resistor and demagnetizing variable resistor.

Terminal wiring diagram

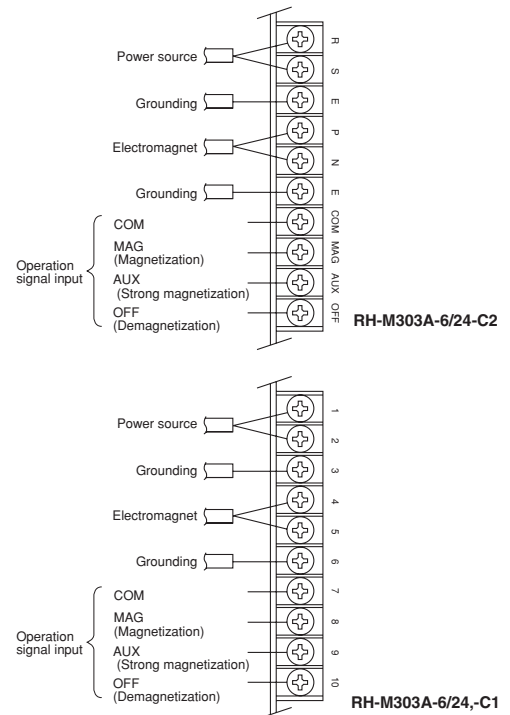

Model RH-H RECTIFIER FOR HYBRID HOLDER



RH-H303A-C2

[Application]

A rectifier dedicated to hybrid holders.

- The employment of FET in the output circuit ensures high-speed and consistent demagnetization performance. These rectifiers also withstand frequent usage.
- A wide range of power source from 100 VAC to 220 VAC can be used.

Model	Type	Input	Output	Dimensions		Applicable Holder	Mass
				[mm (in.)]			
RH-H303A	Type installed inside panel	Single-phase 100 VAC - 220 VAC, 50/60 Hz	0VDC - 24VDC 3A	W55 (2.16) × D160 (6.29) × H175 (6.88)		KE-2HA-8HA	0.8kg/ 1.76 lb
RH-H303A-C2	Type housed in case			W175 (6.88) × D100 (3.93) × H190 (7.48)			2.4kg/ 5.29 lb

※For ON/OFF control, external control is required. Input signals are to be provided by the customer.

Model KR RECTIFIER FOR ELECTROMAGNETIC/PERMANENT ELECTROMAGNETIC HOLDER

Dedicated to electromagnetic/permanent electromagnetic holders



KR-T101A-6/24

[Application]

A standard type to rectify an input from an AC power source to DC and output it to electromagnetic holders.

[Features]

- This model comes in various output voltages and output currents selectable according to required capacities.
- Compact design for installation inside the control panel.
- Since a power cord is equipped as a standard accessory, it can be used simply by connecting an electromagnet.
- Since external control terminals are provided as a standard accessory, it can be used for automatic operation also.

Model	Input		Output		Dimensions			Reverse Excitation Circuit	Applicable Holder	Mass
	Voltage	Fuse	Voltage	Current	Width	Depth	Height			
KR-T101A-6/24	Single-phase 100 VAC, 50/60 Hz	1A	6/24 VDC	1A	155 (6.10)	140 (5.51)	95 (3.74)	-	KE-1B-4B KE-2R-4RA KE-2D-4E KEP-3C-9C,K5	3kg/6.61 lb
KR-N101A		1A	90 VDC	1A	100 (3.93)	106 (4.17)	77 (3.03)		KE-K310A KE-K515A KE-V306-312	
KR-N103A		3A		3A					KE-5B-9B KE-5E,6E	KE-M KE-V510-830

※Power cable (2 m) and plug included.

Electromagnetic Holders and Applicable Rectifiers and Controllable Number of Holders

All holders connected in parallel.

Electromagnetic holder KE-B Series

(Unit: units)

Rectifier	Holder	KE-1B	KE-1.5B	KE-2B	KE-3B	KE-4B	KE-5B	KE-6B	KE-7B	KE-8B	KE-9B
KR-T101A-6 / 24		4	10	11	4	3					
RH-M303A-6 / 24,-C1,-C2		15	33	38	14	11					
RH-M105B-24			56	64	23	18					
KR-N101A							6	4	4	3	2
KR-N103A							20	12	12	9	7
RH-M102C							15	9	9	6	5
RH-M105B							37	23	22	17	12

Thin electromagnetic holder KE-D/E Series

Rectifier	Holder	KE-2D	KE-3E	KE-4E	KE-5E	KE-6E
KR-T101A-6 / 24		20	9	6		
RH-M303A-6 / 24,-C1,-C2		67	30	22		
RH-M105B-24		112	52	37		
KR-N101A					18	12
KR-N103A					54	36
RH-M102C					40	27
RH-M105B					102	69

Auto release type electromagnetic holder KE-R Series

Rectifier	Holder	KE-2R	KE-3RA	KE-4RA
KR-T101A-6 / 24		20	9	6
RH-M303A-6 / 24,-C1,-C2		67	30	22
RH-M105B-24		112	52	37

Rectangular thin electromagnetic holder KE-K Series

Rectifier	Holder	KE-K310A	KE-K315A	KE-K510A	KE-K515A
KR-T101A-6 / 24		7	4	4	2
RH-M303A-6 / 24,-C1,-C2		24	13	15	9
RH-M105B-24		40	22	26	15

Permanent electromagnetic holder KEP-C Series

Rectifier	Holder	KEP-3C	KEP-4C	KEP-5C	KEP-7C	KEP-9C	KEP-K5
KR-T101A-6 / 24		1	1	1	1	1	1
RH-M303A-6 / 24,-C1,-C2		6	5	4	5	6	6

Hybrid holder KE-HA Series

Rectifier	Holder	KE-2HA	KE-3HA	KE-4HA	KE-5HA	KE-6HA	KE-8HA
RH-H303A		38	24	18	13	12	9
RH-H303A-C2							

Calculation of controllable number of units

$$\text{Controllable number of units} = \frac{\text{Output current of rectifier}}{\text{Current of electromagnetic holder}} \times \text{approx. 0.8 (figures below decimal point omitted)}$$

※ "×0.9" for RH-M and RH-H.

(Example)

$$\text{In the case of } \begin{cases} \text{KR-T101A-6/24} \\ \text{KE-2B} \end{cases} \frac{1}{0.07} \times 0.8 \left(\begin{matrix} \text{value 11.428} \\ \dots \text{thus 11} \end{matrix} \right) \text{ Number of units} = 11$$

ELECTROMAGNETIC CHUCKS
CHUCK CONTROLLERS
PERMANENT ELECTROMAGNETIC CHUCKS
PERMANENT ELECTROMAGNETIC CHUCKS
BLOCKS FOR MC
VACUUM CHUCKS
PROMELTA* SYSTEM
SINE BAR CHUCKS
BLOCKS HOLDERS, MINI CHUCKS
HOLDING TOOLS
MEASURING TOOL HOLDERS
MAGNETIC HOLDERS
MAGNETIC TOOLS

MAGNETIC HOLDERS

Model KM PERMANENT MAGNETIC HOLDER

List of permanent magnetic holders

Size	Height	OD "h" Tolerance	Plating	Painting	Peripheral Knurling	Stainless Steel Spec.	Heat-Resistance Spec.
φ 5	× 8	KM-0005					
	× 13		KM-0005L				
φ 7	× 8	KM-0007					
	× 13		KM-0007L				
φ 10	× 8		KM-0010H		KM-0010J	KM-0010H-SUS	
	× 15	KM-H001	KM-001				
	× 18		KM-T001				
φ 15	× 15	KM-H0015	KM-0015				
	× 18		KM-T0015				
φ 18	× 8		KM-0018H		KM-0018J	KM-0018H-SUS	
φ 20	× 15	KM-H002	KM-002				
	× 18		KM-T002				
φ 25	× 10		KM-0025H		KM-0025J	KM-0025H-SUS	
	× 25	KM-H0025		KM-025C			
φ 26	× 25						
	× 30		KM-T0025				
φ 30	× 25				KM-03C		
	× 33				KM-T003		
φ 40	× 30				KM-04C		
φ 40	× 40						KM-T004T
φ 50	× 40				KM-05C		
φ 50	× 45						KM-T005T
φ 70	× 40				KM-07C		
φ 80	× 45				KM-08C		
26 × 26	× 25				KM-025S		
26 × 60	× 25				KM-06S		

[Application]

Can be used to hold down drawings, rules and paper patterns. The holders with a tapped hole on the back can be used widely by installing them on jigs. Can be incorporated in press dies. Can hold workpieces during wire cutting.

[Features]

- Six types of specifications; OD tolerance, plating, painting, peripheral knurling, stainless steel spec. and heat-resistance spec. are available for selection according to applications.
- By matching the OD "h" tolerance, the holders can be incorporated in dies.
- A tapped hole on the back makes the holders useful in various applications.

Embedded in a jig (Example)

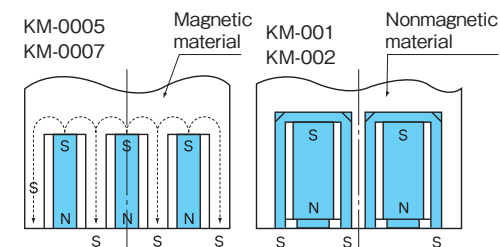

Names of faces

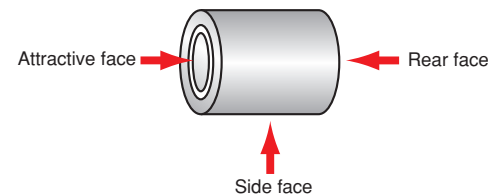

Upper limit of working temperature

The holding power drops as body temperature rises. The following types are available. The original holding power returns to the original level when the temperature drops to normal temperature.

■ Type A (Alnico magnet used)

Superior in terms of temperature. The holding power as high as 85% can be maintained at 350°C when the holding power at 20°C is 100%. This type can be used up to 400°C intermittently for a short period of time.

■ Type B (Samarium-cobalt type rare earth magnet used)

The holding power drops to about 95% at 100°C and to about 85% at 200°C when the holding power at 20°C is 100%. For continuous use, the upper limit is 150°C and for intermittent use for a short period of time, this type may be used up to 200°C.

■ Type C (Neodymium rare earth magnet used)

The holding power drops to about 85% at 50°C and to about 70% at 100°C when the holding power at 20°C is 100%. The upper limit for continuous use is 100°C.

KM-0005 KM-0007 KM-001 KM-0015 KM-002 KM-025C KM-03C KM-04C	KM-05C KM-07C KM-08C KM-0005L KM-0007L KM-H KM-T	KM-025S KM-06S

※ The holding power may drop when the holder is worked on additionally. In particular, additional work in the radial direction has large influence on the holding power and therefore, must be limited to a minimum necessary scope. area: Additionally workable.

indicates the attractive face.



↑ indicates the attractive face.

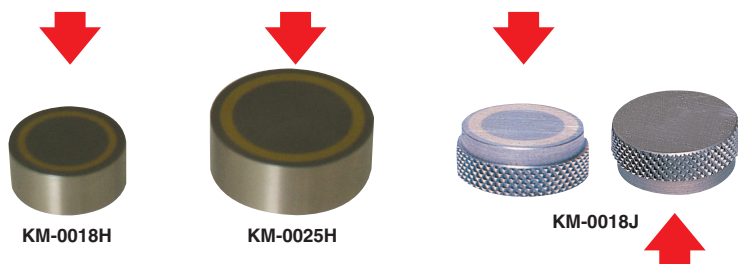

An example of application

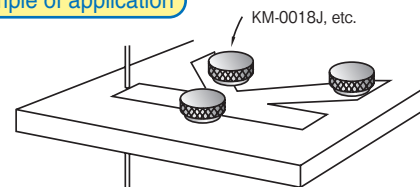

These holders can be used to hold pieces cut out by wire cutting to prevent them from moving or falling from the securing area.

OD "h" tolerance specification

Model	Dimensions			Holding Power	Surface Treatment	Mounting Tapped Hole	Workable Range				Upper Limit of Working Temp.	Tapping	Mass
	OD × Height	"h" tolerance	Height tolerance				D ₁	D ₂	H ₁	H ₂			
KM-0005	φ5 (0.19) h7 (0.27) × 8 (0.31)	$-\frac{0}{-0.012}$	0 -0.1	0.3N (0.03kgf)	None	None	5 (0.19)	4.5 (0.17)	—	—	Type B	Not allowed.	1.5g/0.003 lb
KM-0007	φ7 (0.27) h7 (0.27) × 8 (0.31)	$-\frac{0}{-0.015}$		0.4N (0.04kgf)			7 (0.27)	6.5 (0.25)					2.5g/0.005 lb
KM-H001	φ10 (0.39) h9 (0.35) × 15 (0.59)	$-\frac{0}{-0.036}$		8N (0.8kgf)			10 (0.39)	9.5 (0.37)	11g/0.024 lb				
KM-H0015	φ15 (0.59) h9 (0.35) × 15 (0.59)	$-\frac{0}{-0.043}$		20N (2kgf)			15 (0.59)	14 (0.55)	20g/0.044 lb				
KM-H002	φ20 (0.78) h9 (0.35) × 15 (0.59)	$-\frac{0}{-0.052}$		40N (4kgf)			20 (0.78)	18 (0.70)	40g/0.088 lb				
KM-H0025	φ26 (1.02) h9 (0.35) × 25 (0.98)	$-\frac{0}{-0.052}$	100N (10kgf)	26 (1.02)	24 (0.94)	100g/0.222 lb							

※The holding power is based on a test piece of SS400, 10 mm thick, ground surface. ※The holding power may drop when the holder is worked on additionally. In particular, additional work in the radial direction has large influence on the holding power and therefore, must be limited to a minimum necessary scope.

Plating specification

Model	OD × Height	Holding Power	Surface Treatment	Mounting Tapped Hole	Workable Range				Upper Limit of Working Temp.	Tapping	Mass	
					D ₁	D ₂	H ₁	H ₂				
KM-0005L	φ5 (0.19) × 13 (0.51)	1.8N (0.18kgf)	Nickel plating	None	—	—	13 (0.51)	12 (0.47)	Type A	Not allowed.	2g/0.004 lb	
KM-0007L	φ7 (0.27) × 13 (0.51)	4N (0.4kgf)			7 (0.27)	6.5 (0.25)	3.8g/0.008 lb					
KM-0010H	φ10 (0.39) × 8 (0.31)	3N (0.3kgf)			—	—	5g/0.011 lb					
KM-001	φ10 (0.39) × 15 (0.59)	8N (0.8kgf)			M5 (0.19) Depth5 (0.19) pitch0.8 (0.03)	10 (0.39)	9.5 (0.37)	15 (0.59)	12 (0.47)	Type A	Prepared hole up to 3.0 deep on the rear face allowed.	11g/0.024 lb
KM-T001	φ10 (0.39) × 18 (0.70)										18 (0.70)	Provided.
KM-0015	φ15 (0.59) × 15 (0.59)	20N (2kgf)			None	15 (0.59)	14 (0.55)	15 (0.59)	12 (0.47)	Type A	Prepared hole up to 3.0 deep on the rear face allowed.	20g/0.044 lb
KM-T0015	φ15 (0.59) × 18 (0.70)										M5 (0.19) Depth5 (0.19) pitch0.8 (0.03)	18 (0.70)
KM-0018H	φ18 (0.70) × 8 (0.31)	50N (5kgf)			None	—	—	—	—	Type B	Not allowed.	16g/0.035 lb
KM-002	φ20 (0.78) × 15 (0.59)	40N (4kgf)									M5 (0.19) Depth5 (0.19) pitch0.8 (0.03)	20 (0.78)
KM-T002	φ20 (0.78) × 18 (0.70)				18 (0.70)	Provided.	45g/0.100 lb					
KM-0025H	φ25 (0.98) × 10 (0.39)	90N (9kgf)			None	—	—	—	—	Type B	Not allowed.	38g/0.083 lb
KM-T0025	φ26 (1.02) × 30 (1.18)	100N (10kgf)			M6 (0.23) Depth10 (0.39) pitch1.0 (0.03)	26 (1.02)	24 (0.94)	30 (1.18)	21 (0.82)	Type A	Provided.	120g/0.266 lb
KM-T003	φ30 (1.18) × 33 (1.29)	150N (15kgf)			M6 (0.23) Depth8 (0.31) pitch1.0 (0.03)	30 (1.18)	27 (1.06)	33 (1.29)	28 (1.10)			180g/0.400 lb

※The holding power is based on a test piece of SS400, 10 mm thick, ground surface. ※The holding power may drop when the holder is worked on additionally. In particular, additional work in the radial direction has large influence on the holding power and therefore, must be limited to a minimum necessary scope.

Peripheral knurling specification

Model	OD × Height	Holding Power	Surface Treatment	Mounting Tapped Hole	Upper Limit of Working Temp.	Feature	Mass
KM-0010J	φ10 (0.39) × 8 (0.31)	3N (0.3kgf)	Nickel plating	None	Type B	Peripheral knurling	5g/0.011 lb
KM-0018J	φ18 (0.70) × 8 (0.31)	50N (5kgf)					16g/0.035 lb
KM-0025J	φ25 (0.98) × 10 (0.39)	90N (9kgf)					38g/0.083 lb

※The holding power is based on a test piece of SS400, 10 mm thick, ground surface.

First in the industry! Stainless steel to resist rusting.

↑ indicates the attractive face.



Comparison in pure water (Left: Made of stainless steel)

Working up to 0.5 mm allowed on the attractive face.

Stainless steel specification

Model	OD × Height	Holding Power	Surface Treatment	Mounting Tapped Hole	Upper Limit of Working Temp.	Tapping	Mass
KM-0010H-SUS	φ10 (0.39) × 8 (0.31)	3N (0.3kgf)	None	None	Type B	Not allowed.	5g/0.011 lb
KM-0018H-SUS	φ18 (0.70) × 8 (0.31)	50N (5kgf)					16g/0.035 lb
KM-0025H-SUS	φ25 (0.98) × 10 (0.39)	90N (9kgf)					38g/0.083 lb

※The holding power is based on a test piece of SS400, 10 mm thick, ground surface.

ELECTROMAGNETIC CHUCKS
CHUCK CONTROLLERS
PERMANENT ELECTROMAGNETIC CHUCKS
PERMANENT ELECTROMAGNETIC CHUCKS
BLOCKS FOR MC
VACUUM CHUCKS
PROMELTA* SYSTEM
SINE BAR CHUCKS
BLOCKS HOLDERS, MINI CHUCKS
HOLDING TOOLS
MEASURING TOOL HOLDERS
MAGNETIC HOLDERS
MAGNETIC TOOLS

MAGNETIC HOLDERS

Model KM PERMANENT MAGNETIC HOLDER

↑ indicates the attractive face.

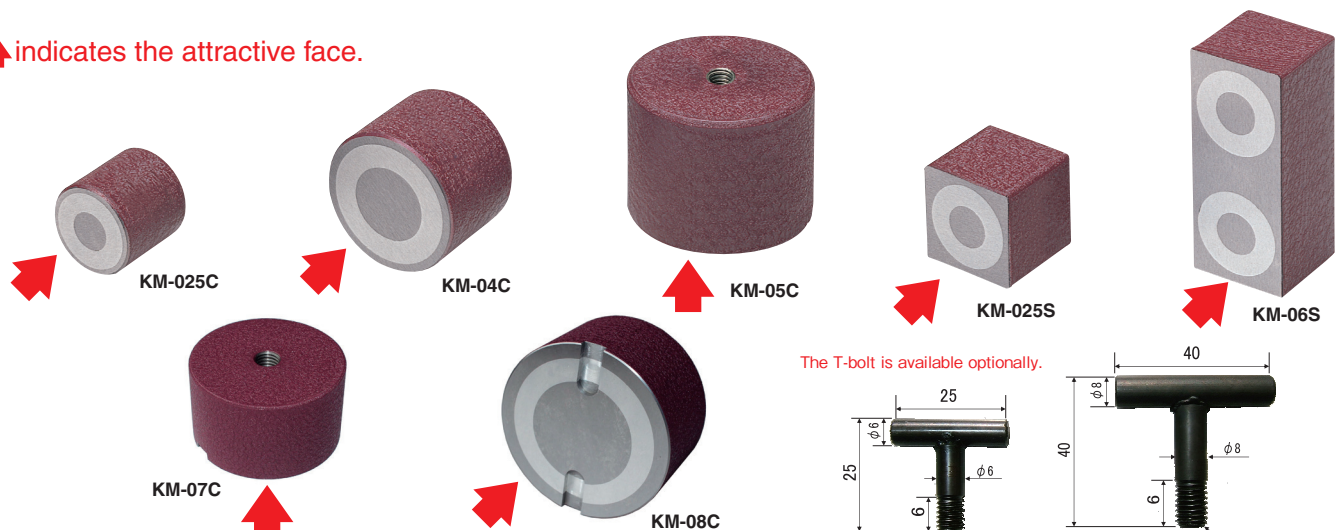

Painting specification

Model	OD × Height	Holding Power	Surface Treatment	Mounting Tapped Hole	Workable Range				Upper Limit of Working Temp.	Tapping	Mass
					D ₁	D ₂	H ₁	H ₂			
KM-025C	φ26 (1.02) × 25 (0.98)	100N (10kgf)	Painting	M 6 (0.23), depth 8 (0.31) pitch 1.0 (0.03)	26 (1.02)	25 (0.98)	25 (0.98)	17 (0.66)	Type C (See page 81)	Provided.	90g/0.19 lb
KM-03C	φ30 (1.18) × 25 (0.98)	150N (15kgf)			30 (1.18)	27 (1.06)					20 (0.78)
KM-04C	φ40 (1.57) × 30 (1.18)	300N (30kgf)		M 8 (0.31), depth 12 (0.47) pitch 1.25 (0.04)	40 (1.57)	36 (1.41)	30 (1.18)	260g/0.57 lb			
KM-05C	φ50 (1.96) × 40 (1.57)	500N (50kgf)			50 (1.96)	46 (1.81)	545g/1.20 lb				
KM-07C	φ70 (2.75) × 40 (1.57)	700N (70kgf)		M12 (0.47), depth 15 (0.59) pitch 1.75 (0.06)	70 (2.75)	60 (2.36)	40 (1.57)	25 (0.98)			1000g/2.20 lb
KM-08C	φ80 (3.14) × 45 (1.77)	1000N (100kgf)		M12 (0.47), depth 18 (0.70) pitch 1.75 (0.06)	80 (3.14)	66 (2.59)	45 (1.77)	27 (1.06)			1600g/3.52 lb
KM-025S	26 (1.02) × 26 (1.02) × 25 (0.98)	100N (10kgf)		None	26 (1.02)	25 (0.98)	25 (0.98)	15 (0.59)			Prepared hole up to 11 deep on the rear face allowed.
KM-06S	26 (1.02) × 60 (2.36) × 25 (0.98)	200N (20kgf)	M6 (0.23), depth 10 (0.39) pitch 1.0 (0.03)	60 (2.36)	25 (0.98)	25 (0.98)	15 (0.59)	Provided	275g/0.60 lb		

*The holding power is based on a test piece of SS400, 10 mm thick, ground surface.

Model KM-T-T HEAT-RESISTANT PERMANENT MAGNETIC HOLDER

↑ indicates the attractive face.

A heat-resistant type introduced to permanent magnetic holders!

[Application]

Most suitable as a securing fixture in workplaces where heat is generated such as ship building and welding sites. These holders can also be used to hold down drawings, rulers and small parts.

[Features]

- Heat resistance up to 350°C
- The tapped hole provided on the back widens a scope of use by assembling these holders to fixtures.

[mm (in)]

Model	OD × Height	Holding Power	Surface Treatment	Mounting Tapped Hole	Upper Limit of Working Temp.	Tapping	Mass
KM-T004T	φ40 (1.57) × 40 (1.57)	300N (30kgf)	Painting	M8 (0.31) depth 10 (0.39) pitch 1.25 (0.04)	Max. 350°C	Provided.	0.4kg/0.88 lb
KM-T005T	φ50 (1.96) × 45 (1.77)	500N (50kgf)					0.67kg/1.47 lb

*The holding power is based on a test piece of SS400, 10 mm thick, ground surface.

Model KM-RB HEXAGONAL PERMANENT MAGNETIC HOLDER (WITH MALE THREAD)

Model KM-RT HEXAGONAL PERMANENT MAGNETIC HOLDER (WITH PLATE)

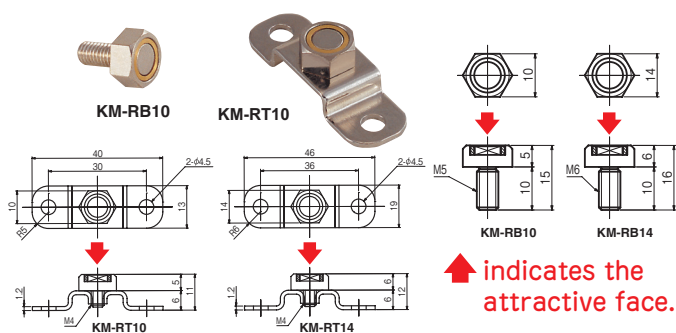

[Application]

Used as a jig. Used for operations of conveying light weight workpieces in lines, etc.

[Features]

- The tip of the permanent magnetic holder is threaded, which enables the holder to be mounted in any place easily.
- When used in combination with the included plate, the holder can be mounted in places where a tapped hole cannot be made. (Model KM-RT)
- Since this holder has been nickel plated, it can be used under various circumstances.

Model	Holding Power	Mass	Model	Holding Power	Mass
KM-RB10	10N (1kgf)	5g/0.011 lb	KM-RT10	10N (1kgf)	10g/0.022 lb
KM-RB14	40N (4kgf)	10g/0.022 lb	KM-RT14	40N (4kgf)	18g/0.039 lb

*The holding power is based on a test piece of SS400, 10 mm thick, ground surface.

Model KOK ALL-CATCH

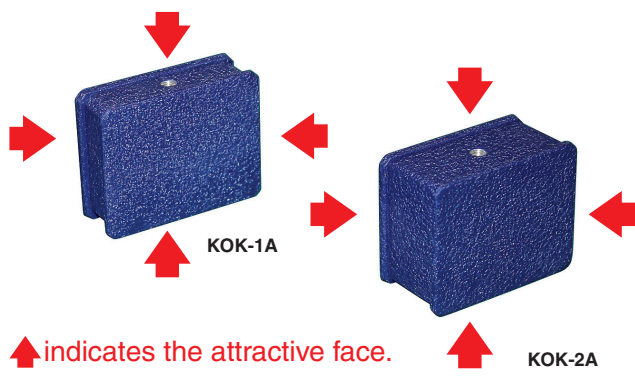

[Application]

Versatile holders having four attractive faces to meet various applications. These holders also have threaded holes to enable fixtures to be mounted for coupling of holders.

Model	Holding Power	Dimensions			Tapped Hole	Mass
		B	L	H		
KOK-1A	200N (20kgf)	17.0 (0.66)	50 (1.96)	40 (1.57)	M5 (0.19) × 0.8 (0.03) Depth, 5 (0.19)	150g / 0.33 lb
KOK-2A	300N (30kgf)	27.6 (1.08)				280g / 0.61 lb

※The holding power is based on a test piece of SS400, 10 mm thick, ground surface.

Model KOC CABLE HANGER

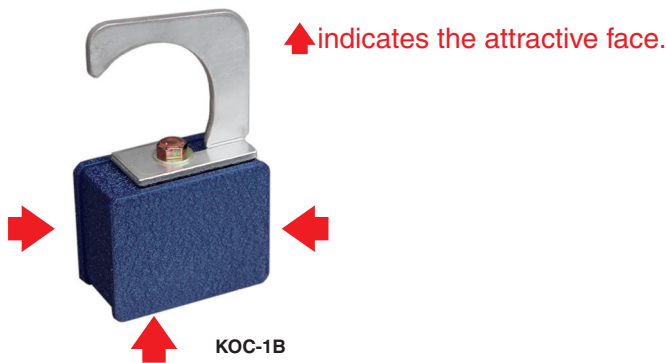

[Application]

Very useful for holding welding cables and for putting jigs and fixtures in order on work sites of shipbuilding, iron and steel manufacturing, bridge building, canneries and similar operations.

[Features]

- Strong holding power capable of destacking stacked thin iron sheets.
- With the lateral sliding resistance of 80N (8kgf), this hanger generates sufficient holding power as a hanger.

Model	Holding Power	Dimensions			Mass
		B	L	H	
KOC-1B	300N (30kgf)	50 (1.96)	27.6 (1.08)	40 (1.57)	400g / 0.88 lb

※The holding power is based on a test piece of SS400, 10 mm thick, ground surface.
※The hook part is 87 mm high.

Model KOC MAGHANGER*

Powerful type



Dedicated hanger included

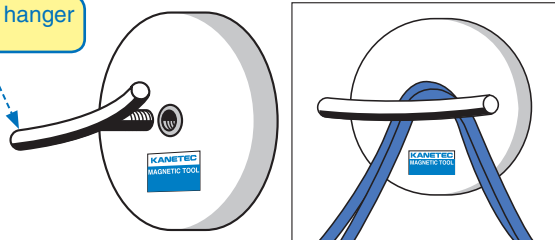

[Application]

Powerful magnetic hanger holders most suitable for cabling and temporary wiring work on sites. Applicable to a wide range of uses as a hanger, since these hangers powerfully attach to thin steel sheets, steel lockers, refrigerators, etc.

Model	Holding Power	Dimensions		Grip Mounting Thread	Mass
		φ	Length		
KOC-70	130N (13kgf)	φ66 (2.59)	× 11 (0.43)	M6 (0.23) × 1.0 (0.03) depth 5 (0.19)	210g / 0.46 lb
KOC-80	300N (30kgf)	φ80 (3.15)	× 13 (0.51)		330g / 0.72 lb

※The holding power is based on a test piece of SS400, 10 mm thick, ground surface.

Model WK POWERFUL MAGNETIC HOLDER



[Application]

Suitable as holding tools for tentative installation and tack welding on such work sites as construction, bridge, shipbuilding and piping.

[Features]

- There are three faces where additional machining (such as drilling) can be done. (Refer to the dimension drawing)
- The exterior is made of aluminum to prevent adhesion of iron powder to the top and side faces.
- Model WK-TPA has a construction that is highly resistant to heat.

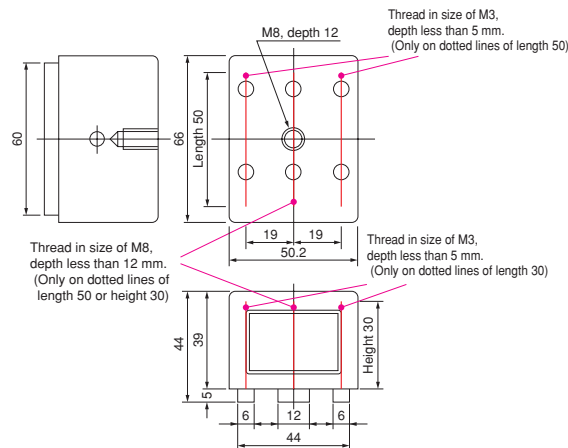

WK-P/TPA

↑ indicates the attractive face.

Model	Heat Resistance	Holding Power	Mass
WK-P	60°C	1000N (100kgf)	0.75kg / 1.65 lb
WK-TPA	180°C		

※The holding power is based on a test piece of SS400, 10 mm thick, ground surface.

ELECTROMAGNETIC CHUCKS
CHUCK CONTROLLERS
PERMANENT ELECTROMAGNETIC CHUCKS
PERMANENT ELECTROMAGNETIC CHUCKS
BLOCKS FOR MC
VACUUM CHUCKS
PROMELTA* SYSTEM
SINE BAR CHUCKS
BLOCKS HOLDERS, MINI CHUCKS
HOLDING TOOLS
MEASURING TOOL HOLDERS
MAGNETIC HOLDERS
MAGNETIC TOOLS